

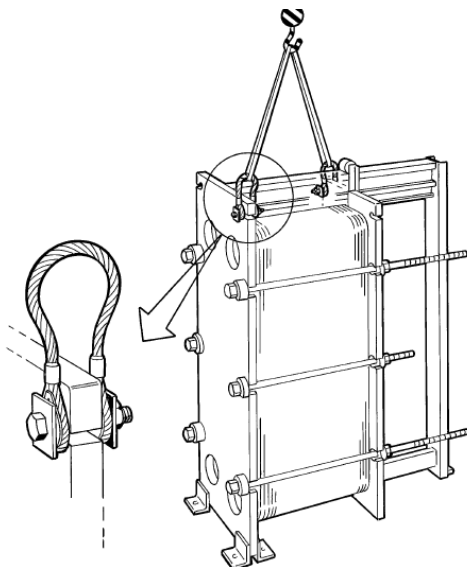

# BAODE GASKET PHE

# 安装

## Installation

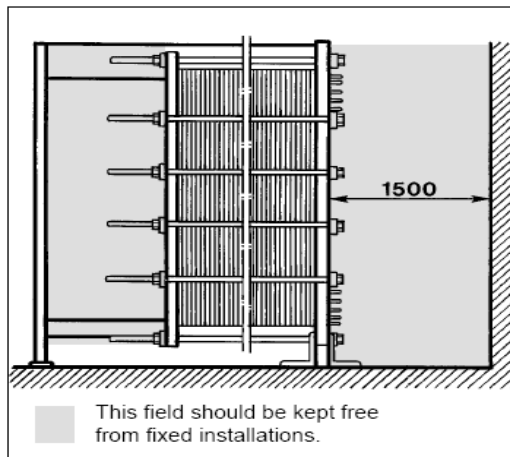
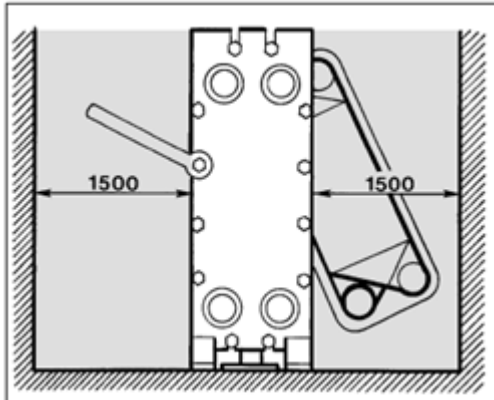

当将管道与换热器连接时，要确保没有任何应力或迫害力通过管道作用在换热器上。

Before connecting any pipe to the heat exchanger, make sure all foreign projects have been rinsed out of the system.

宝得公司建议将板式换热器安装在可给予其框架以及必要支承的平整基础上。该基础不需要特别的锚固定设施。重要的是在其周围要留有自由空间（参考图）。除了要将板片从换热器移出或放进框架所需空间外，维修服务并不需要其他空间。

As will appear from the dimension drawing provided by BAODE, and from the picture above, it is necessary to leave free space around the apparatus, to give access and make future service possible. Except for a place to put the plates, if removed from the heat exchanger, no further space is required for servicing the apparatus.

The measurements given in the picture are recommended by BAODE, to provide reasonably good working conditions, during installation of the heat exchanger as well as for future maintenance and service. If floor space is restricted then the dimensions suggested can be reduced, and it is left to the purchaser to decide just how much access space can be left.

如果要起吊整个换热器，请使用吊环，吊环设置如左图。注意，严谨吊在拉杆螺栓或换热器接口上。

If you are to lift the heat exchanger itself, straps should be used. They should be placed as shown on the picture

### WARNING!

Never lift by the connections or the studs around them.



## 1. 结构 Construction

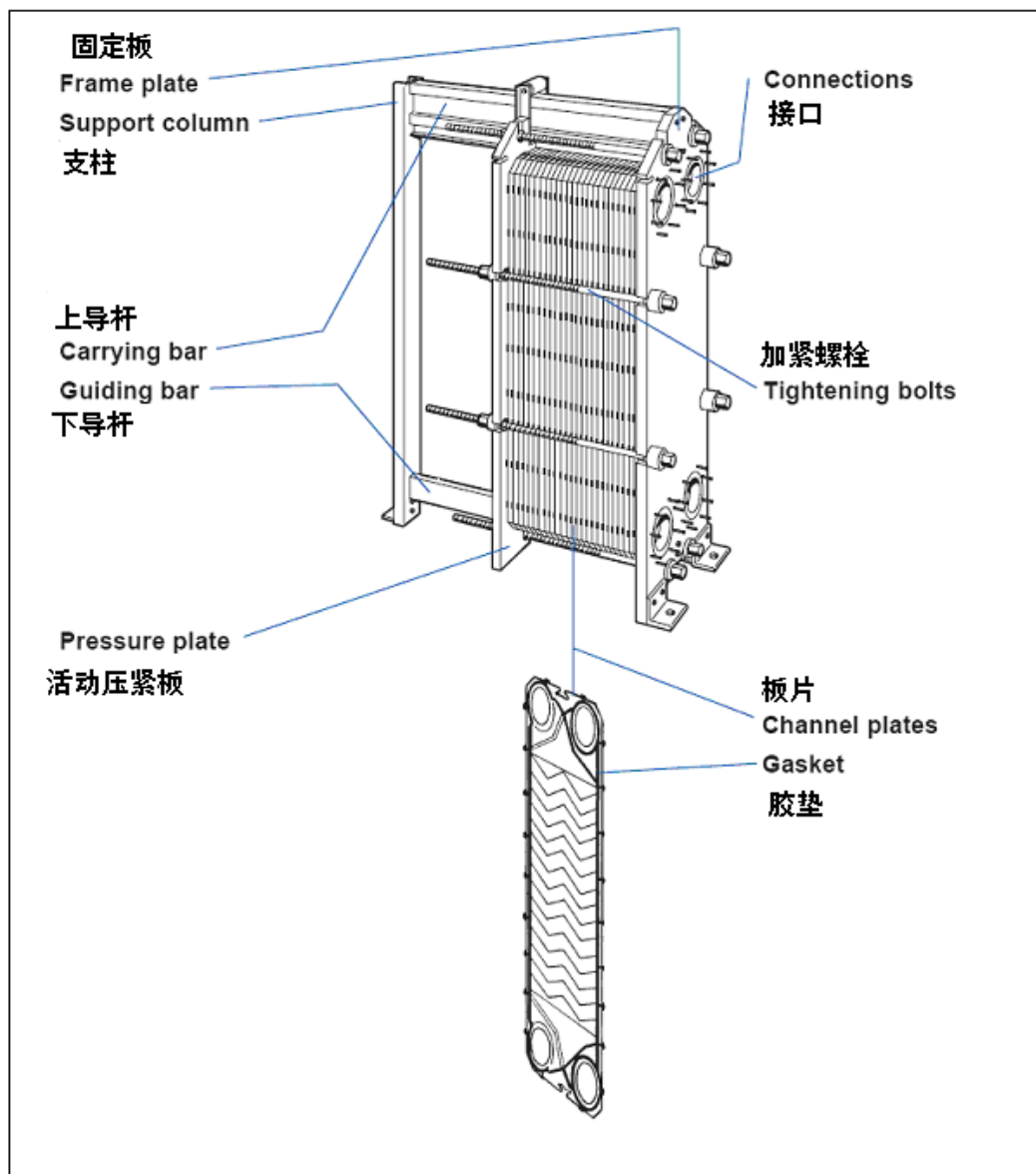

传热板片通过本身的吊挂孔挂在上导杆上，并被固定板和活动压紧板夹紧。板片四角开有角孔，周边及角孔处粘有密封垫片。装配时，板片粘有密封垫片的一面朝向活动压紧板，按工艺要求设计的流程图进行装配，形成冷、热两侧流体的流道。冷、热流体由相应的接管进出。传热板片是压制有波纹的金属薄板，相邻两板片之间的空间即为流体流经的流道。冷、热流体在板片两侧流动时，通过板片进行热量交换

The plate pack is assembled between a fix frame plate and a movable pressure plate and compressed by tightening bolts. The plates are fitted with a gasket which seals the interplate channel and directs the fluids into alternate channels. The frame plate and the pressure plate are suspended from an upper carrying bar and located by a lower guiding bar, both of which are fixed to a support column. Connections are located in the frame plate or, if either or both fluids make more than a single pass within the unit, in the frame and pressure plates.

## 工作原理 Work principle:

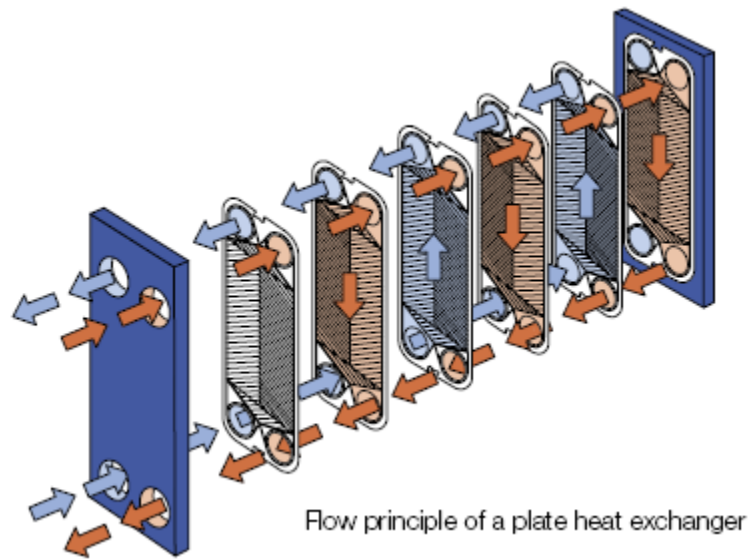

由于传热板片的特殊波纹和特殊配置，流体沿板间弯曲的流道流动，流速大小和流动方向的不不断变化，因而能在低雷诺数（ $Re$  约 200）下激起流体强烈湍动，有力的破坏边界层，减少界面上液膜热阻，强化了传热的过程，因此，获得很高的传热效率。

Channels are formed between the plates and the corner ports are arranged so that the two media flow through alternate channels. The heat is transferred through the plate between the channels, and complete counter-current flow is created for highest possible efficiency. The corrugation of the plates provides the passage between the plates, supports each plate against the adjacent one and enhances the turbulence, resulting in efficient heat transfer

## Starting up

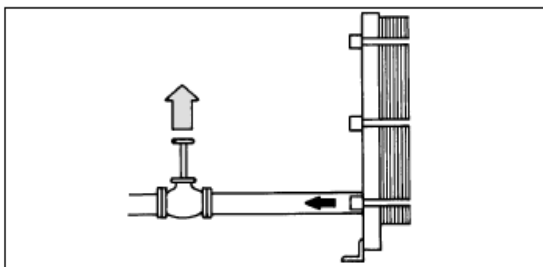
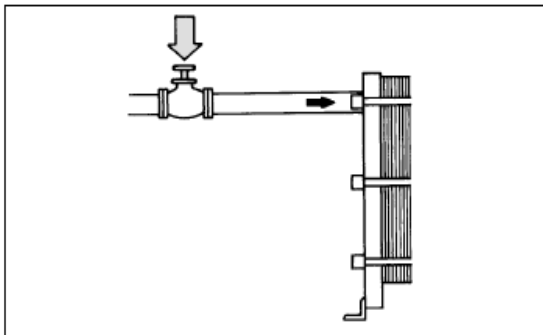
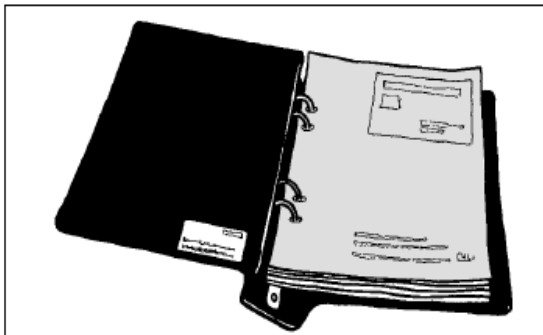
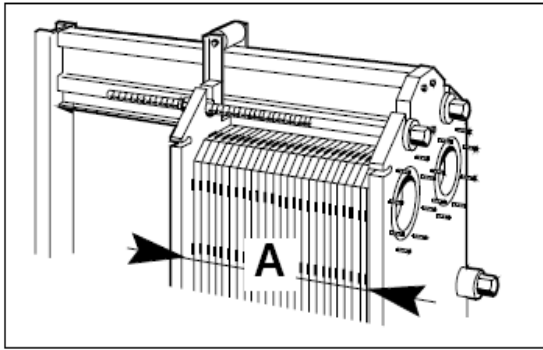

### 开车:

1. 在首次或长时间停运后开车要确保被加紧至正确尺寸A。很重要是换热器连接的系统具有防止温度和压力突然急剧变化的保护设施。这种保护对换热器和管道及系统内的设施均有效。每次运转时包括启动系统中泵时都要牢记。Before starting up for the first time or after a long time of close-down: Make sure that the plate pack is compressed to the right measurement A! Check with the Data-Print, which is located in the inside pocket of the back cover. It is very important that the system to which the heat exchanger is connected, is protected against sudden and extreme variations of temperature and pressure to avoid damages. This applies not only for the heat exchanger but also for the pipe system itself and every piece of equipment included in it. This should be kept in mind whenever a manoeuvre is to be carried out, including starting up of the pumps in the system.
2. 在启动任何泵之前要确认是否有操作说明指令你先启动哪个泵。Before starting any pump, check whether instructions exist, telling you which pump should be started first.
3. 检查开车的系统中位于泵和设备之间用于控制系统流量的阀门是否处于关闭状态 Check that the valve between the pump and the apparatus, controlling the flow rate of the system which you are about to start up is closed.
4. 如出口管路上有阀门，应检查该阀门是否全开 Check that the valve at the exit – if there is one – is fully open.
5. 打开放气孔 Open the vent.
6. 启动泵 Start the pump.
7. 缓慢打开管路上的阀门 Open the valve slowly.
8. 当所有的空气都排出后，关闭放弃孔。When all air is out, close the vent.
9. 关于另一侧重复上述程序 Repeat the procedure for the other media.

## 单元操作 Unit in operation

为保持正确的温度和压力降所需要的任何流速调节约应缓慢的进行，以防止对系统的冲击。换热器运行性能上出现问题的原因可能是温度条件和热负荷的某些变化或是因为结构。只要设备运行良好，就不要对其进行任何干预。

Any adjustment of the flow rates required to maintain correct temperatures or pressure drops should be made slowly, in order to prevent shocks to the system. Problems in keeping up the performance of the heat exchanger may be caused by a change of some of the temperature conditions, the heat load or by fouling. As long as the apparatus is operating to satisfaction, it should be left without any interference.

## 停车 Shut-down

如果换热器要停止运行或由于其他原因泵要停止运行，则遵循以下程序：

If the heat exchanger is going to be shut down – Or if for any reason at all the pumps are to be stopped – the following procedure should be followed:

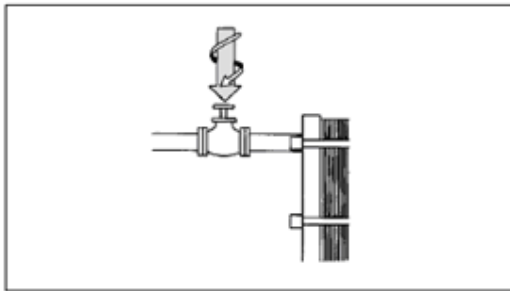

1. 首先确认是否有关于哪一侧应先停止指令。 First establish whether instructions exist as to which side should be stopped first.

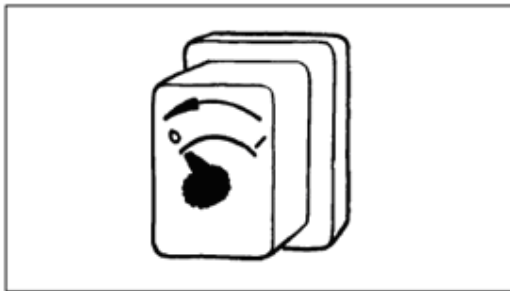

2. 缓慢关闭要停进泵流量的阀门。 Slowly close the valve controlling the flow rate of the pump you are about to stop.

3. 当阀门关闭后，停止泵的运行。 When the valve is closed, stop the pump.

4. 对另一侧重复以上程序。 Repeat the procedure for the other side.

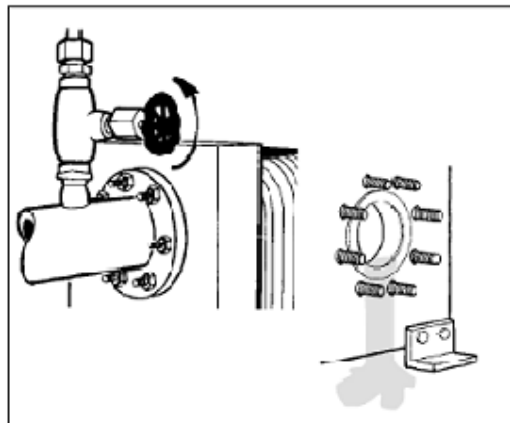

5. 如由于任何原因，换热器长时间停止，则应将它排空，并建议根据所处理的介质情况，经行清洗和干燥。 If for any reason the heat exchanger is shut down for a longer period (more than a number of days), it should be drained, and depending on the media processed, it is recommendable to rinse and dry it.

## 不遵循开停车程序的危险：The risks of not complying with the start-up and shut-down procedures

在管道系统中运动着的液体携带大量的能量，必须小心处理。特别是当流体停供时，必须要妥善地处置。

A liquid in motion in a pipe system represents a lot of energy, and it must be very carefully dealt with. Particularly when the fluid is stopped it is imperative that this is done smoothly. Valves must be operated gradually. The longer the pipes and the higher the flow rate, the more important this becomes.

注意：NOTE!

由于以上理由，除非系统的管道很短，负责不应采用快速关闭阀。阀门必须慢慢地操作。管道越长，流速越高，这一点很重要。

For this reason fast-closing valves should not be used unless the pipes of the system are very short.

水锤现象是指短暂的压力高峰。它作为一种波以声速沿管道传送，并会使封闭系统中流体的运动突然变慢。因此，它通常与系统的突然停车有关。然而，当启动系统而打开阀门和空管道时，流体中可能突然出现某些障碍，如遇到细网滤水器，流量计等，即使流动不停止，也会引起流速的突然减小。所以，我们的系统中也存在产生水锤现象的条件。最坏的情况下，由于流体流动突然停止而引起压力波动可达到系统正常压力的好几倍。所以，十分小心地进行开停车对保护装置十分重要。

WATER HAMMER is the name given to a short-lasting pressure peak, travelling along the pipe as a wave at the speed of sound, and resulting from a sudden deceleration of the motion of the fluid in a closed system.

Thus, it is usually related to the shutting down of a system. However, when starting up a system with open valves and empty pipes, the fluid may burst into some obstacle, like a fine-mesh strainer, a flow meter or a heat exchanger, causing a sudden reduction of the flow velocity – if not a complete halt –, and so we may have the conditions of a Water Hammer. In the worst case, the pressure surge caused by such a sudden stop of the motion of a fluid can be several times the normal pressure of the system.

Therefore it is very important for the protection of the whole installation that start-ups and close-downs are carried out with great care

## 拆卸和组装板片组 Open and Assembly

### 拆卸 Open:

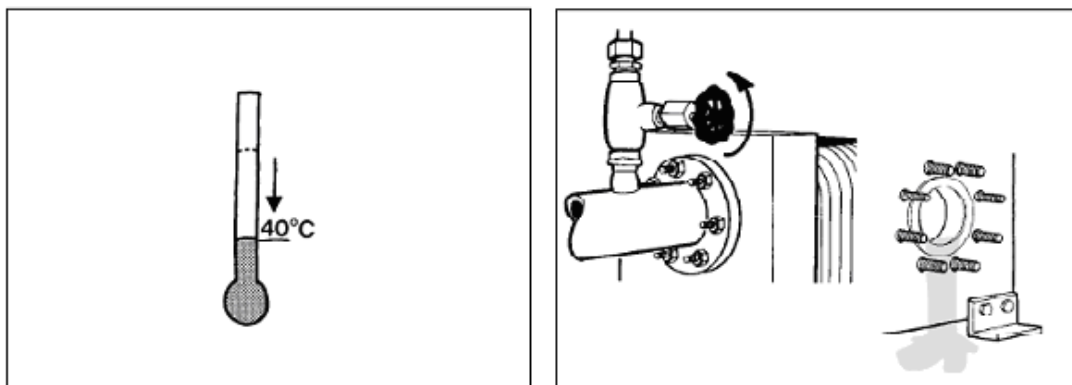

1. 如果换热器处于热态，则等它冷却至40摄氏度。将换热器内液体排空。If the heat exchanger is hot, wait until it has cooled down to about 40°C and drain.

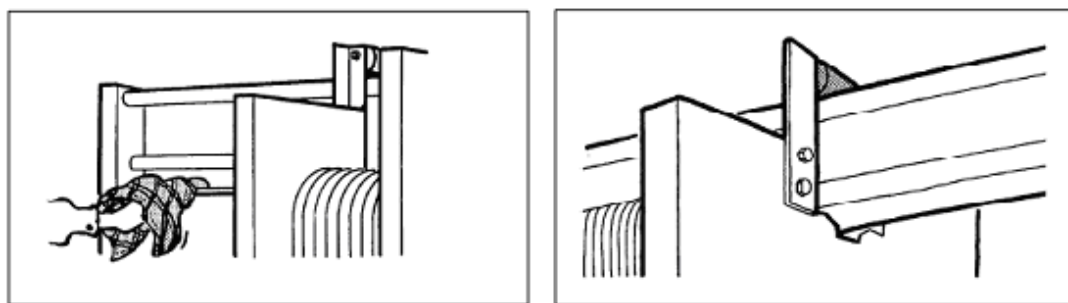

2. 检查支承杆的滑动面，并将其擦干净。Inspect the sliding surfaces of the carrying bar and wipe clean.

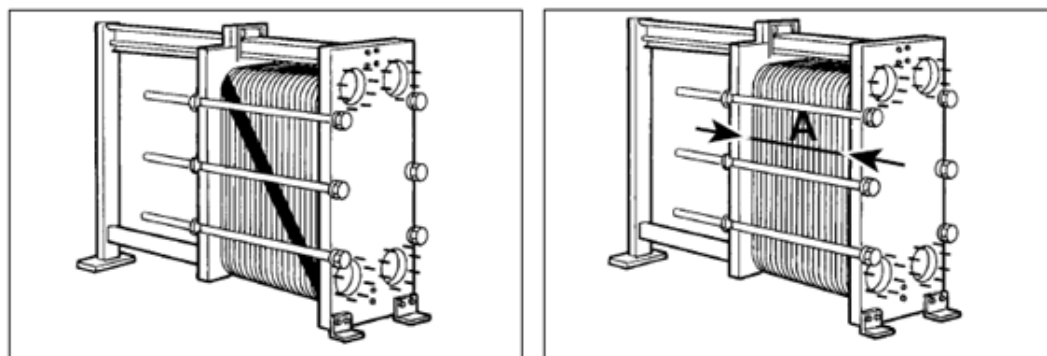

3. 用在板片组外表对角斜线或对板片编顺序号的方式对板片装配作标记，并记下尺寸A。Mark the plate assembly on the outside by a diagonal line, or number the plates in sequence, Measure and note down the dimension A.

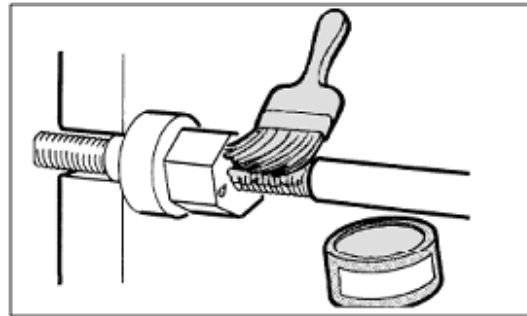
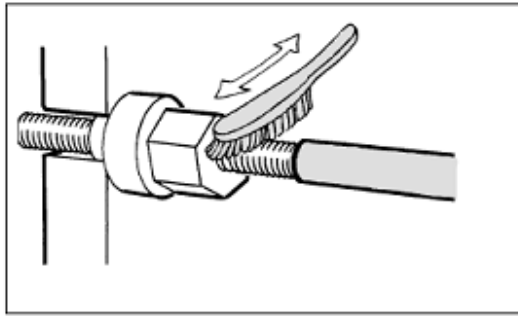

4. 用刷子清理螺栓，并用GLEITMO 800或相当的油脂在螺纹上涂一薄层。  
 Pull back the plastic covers on the tightening bolts; brush the threads clean with a steel wire brush. Lubricate the threads with a thin layer of grease, e.g. Gleitmo 800 or equivalent.

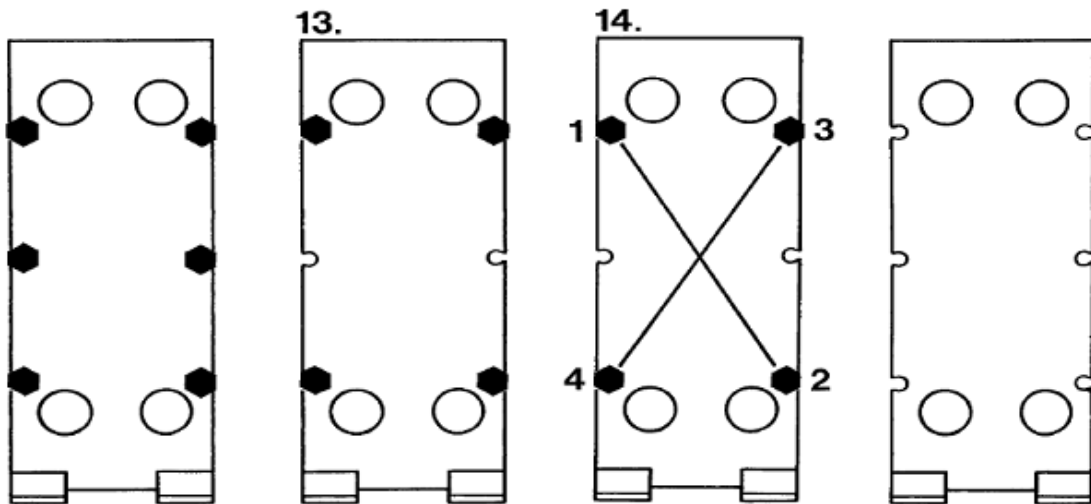

Order	Bolt No.	To dimension
1	1-2-3-4	1.05 A
2	1-2 or 3-4	Opening

5. 打开时以 1-2-3-4 或 1-2 或 3-4 的顺序打开。  
 Please follow the 1-2-3-4 or 1-2,3-4 to loose the bolts.

## 组装 Assembly and Closing

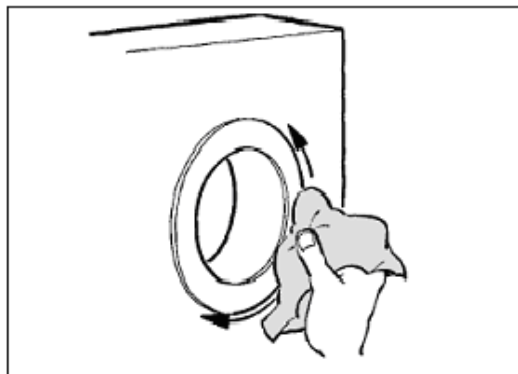
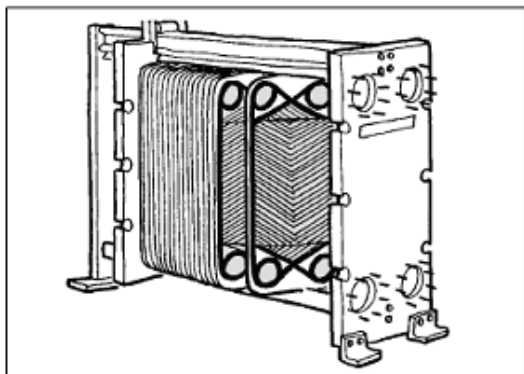

1. 检查并确认所有的密封面都是清洁的，并检查O型密封圈是否位置正确和性能状况。  
Check that all the sealing surfaces (i.e. surfaces in contact with the heat transfer medium) are clean. Check that the ring gaskets, when fitted in connections, are in position and are in good condition.

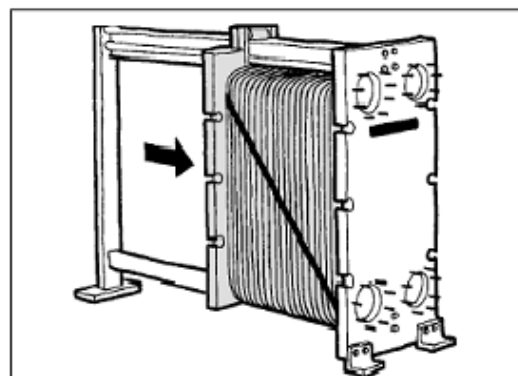
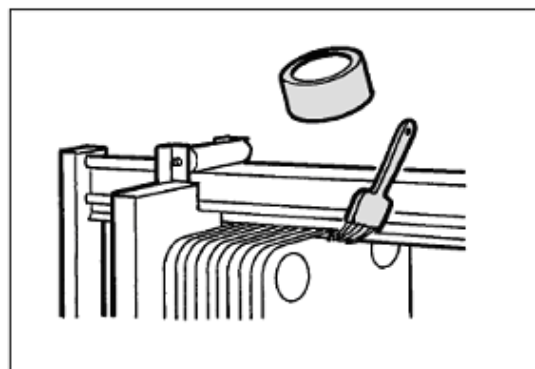

2. 清洁并润滑导杆的轨道Clean and lubricate the sliding surfaces of the carrying bar.
3. 加紧活动板。Press the plate assembly together

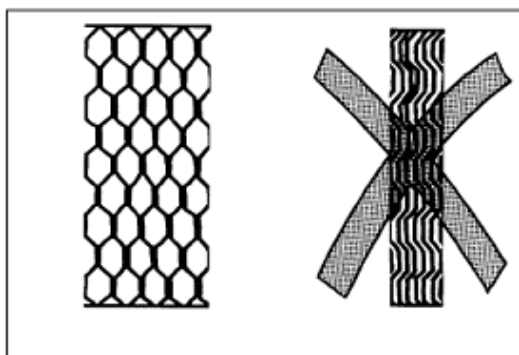

4. 如果板片组装正确，其边缘呈蜂窝状，如果板片做了标记，则检查次标记。If the plates are correctly assembled, the edges form a "honeycomb" pattern. If the plate pack has been marked on the outside (fig.6) check this.

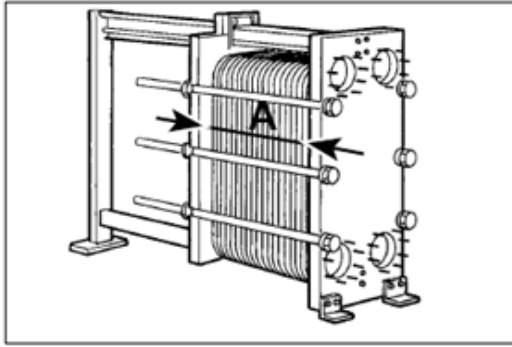

5. 收紧板片是同样按对角循序收紧，加紧是要检查尺寸 A，实际测得的尺寸不得小于 A。When tightening the plates packing, please follow the same procedure of open. And check the dimension A, the actual dimension can not be less than A.

**A 长度。 A length.**

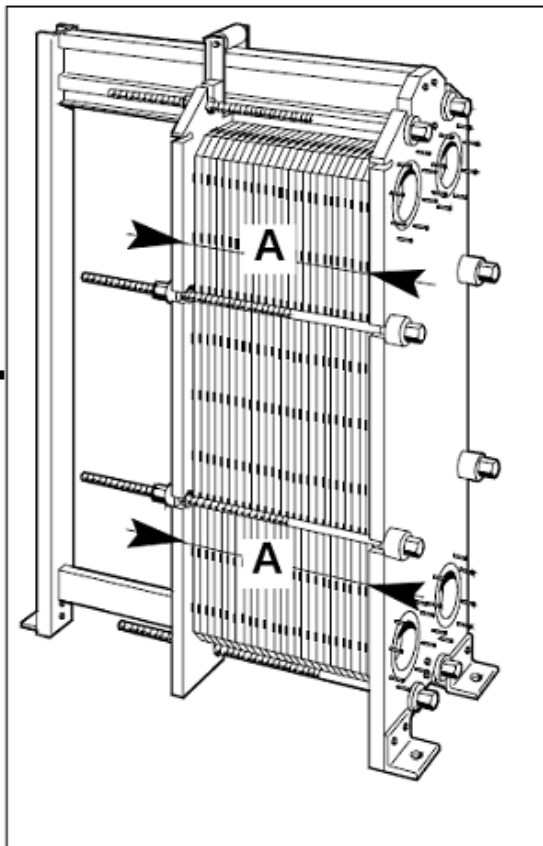

A 的长度计算方法如下 The length of A calculate as below:  $A=N \times \text{_____}$  ,

板片的加紧长度必须在以下范围内。  
The length of the plates packing can not exceed following:

板片加紧厚度/板 Length of the per plate	板片组长度 plates packing length
> 4mm	A+1%
> 3mm, < 4mm	A+1.5%
< 3mm	A+2%

## 维护与清洗 Maintenance and Clean

宝得换热设备有限公司建议对每台板式换热器均应进行正常维护以及特殊维护。这些维护的时间取决于介质的物理与化学性质以及热负荷。Baode suggest you maintain the heat exchanger and clean it when need. The maintenance period depends on the fluids Chemical Properties and the thermal load.

### 1. 正常维护 Regular Maintenance

正常维护通常不需要将板式换热器拆卸开，除非偶尔检查板片和垫片以外。

回流法：视介质性质, 选用适当的易溶液体进行短期逆流循环运行洗涤。

The regular maintenance no need to open the heat exchanger. The methos is use certain weak acid to flush in reverse

### 2. 特殊维护 Special Maintenance

在特殊维护时，应使用天然酸按下列程序进行清洗。酸用量取决于下表中所列的各种污垢的沉积量。

When do special maintenance, use certain liquid clean the plates as following steps, the volum of the liquid depends ont the depostion condition.

1. 拆卸开板式换热器。Open the heat exchanger.
2. 将垫片从板片上取下。Remove the plates from the Heat Exchanger.
3. 用软刷在水流中刷洗。Clean the plates by the soft brush with the stream.
4. 用高压水冲洗。Flush by the pressure water.

(注意：任何情况下均不能对不锈钢板使用盐酸。不能用氯离子含量超过300PPM 的液体。保护铝制支承柱不受化学腐蚀很重要。Note: Under no circumstances should hydrochloric acid be used with **Stainless steel plates**. Water of more than 300 ppm Cl may not be used for the preparation of cleaning solutions. It is very important that carrying bars and support columns in aluminium are protected against chemicals.)

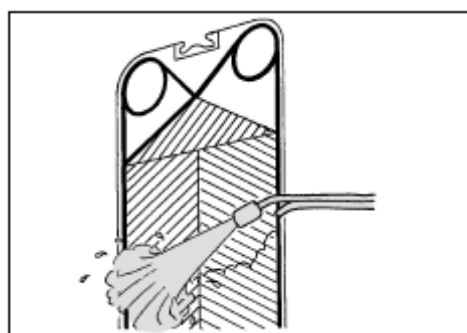
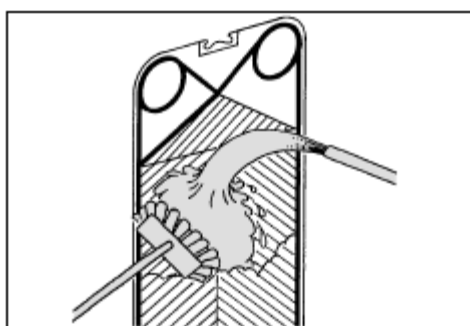

## 清洗 Cleaning

<p><b>生物生长-淤泥</b></p> <ul style="list-style-type: none"> <li>• 细菌</li> <li>• 线虫</li> <li>• 原生动物</li> </ul>	<p><b>Biological growth – slime</b></p> <ul style="list-style-type: none"> <li>• Bacteria</li> <li>• Nematodes</li> <li>• Protozoa</li> </ul>
<p><b>化学清洗用碱性清洗</b></p> <ul style="list-style-type: none"> <li>• 氢氧化钠</li> <li>• 碳酸钠</li> <li>• 少量增加次氯酸盐可以大大增加清洗效果。</li> </ul>	<p><b>Chemical cleaning using alkaline cleaning</b></p> <p>Agents:</p> <ul style="list-style-type: none"> <li>• Sodium hydroxide</li> <li>• Sodium carbonate</li> <li>• Cleaning effect can be considerably increased by the addition of small quantities of hypochlorite or agents for the formation of complexes and surfactants.</li> </ul>
<p><b>*Concentration max 4%.Temperature max 80°C.</b></p> <p><b>*最高浓度 4%， 最高温度 80° C.</b></p>	

<p><b>水垢</b></p> <ul style="list-style-type: none"> <li>• 碳酸钙</li> <li>• 硫酸钙</li> <li>• 硅酸盐</li> </ul>	<p><b>Incrustation – scaling</b></p> <ul style="list-style-type: none"> <li>• Calcium carbonate</li> <li>• Calcium sulphate</li> <li>• Silicates</li> </ul>
<p><b>对打开的换热器用如下液体:</b></p> <ul style="list-style-type: none"> <li>• 硝酸</li> <li>• 氨基磺酸</li> <li>• 柠檬酸</li> <li>• 磷酸</li> <li>• 络合剂（乙二胺四乙酸，国家旅游局）</li> <li>• 钠多磷酸盐</li> </ul>	<p><b>Chemical cleaning on opened unit by using:</b></p> <ul style="list-style-type: none"> <li>• Nitric acid</li> <li>• Sulfamic acid</li> <li>• Citric acid</li> <li>• Phosphoric acid</li> <li>• Complexing agents (EDTA, NTA)</li> <li>• Sodium polyphosphates</li> </ul>
<p><b>*Concentration max 4%.Temperature max 60°C.</b></p> <p><b>*最高浓度 4%， 最高温度 60° C.</b></p>	

## 清洗 Cleaning

<p>沉积物</p> <ul style="list-style-type: none"> <li>• 防腐蚀物</li> <li>• 金属氧化物</li> <li>• 泥沙</li> <li>• 氧化铝</li> <li>• 双原子生物体及其排泄物的不同颜色</li> </ul>	<p><b>Sediment</b></p> <ul style="list-style-type: none"> <li>• Corrosion products</li> <li>• Metal oxides</li> <li>• Silt</li> <li>• Alumina</li> <li>• Diatomic organisms and their excrement of various colours</li> </ul>
<p>对打开的换热器用如下液体:</p> <ul style="list-style-type: none"> <li>• 硝酸</li> <li>• 氨基磺酸</li> <li>• 柠檬酸</li> <li>• 磷酸</li> <li>• 络合剂 (乙二胺四乙酸, 国家旅游局)</li> <li>• 钠多磷酸盐</li> </ul>	<p><b>Chemical cleaning on opened unit by using:</b></p> <ul style="list-style-type: none"> <li>• Nitric acid</li> <li>• Sulfamic acid</li> <li>• Citric acid</li> <li>• Phosphoric acid</li> <li>• Complexing agents (EDTA, NTA)</li> <li>• Sodium polyphosphates</li> </ul>
<p>*Concentration max 4%. Temperature max 60°C. *最高浓度 4%, 最高温度 60° C.</p>	

<p>石油残渣, 沥青和脂肪</p> <ul style="list-style-type: none"> <li>• 石油残留</li> <li>• 沥青</li> <li>• 油脂</li> </ul>	<p><b>Oil residues, asphalt and fats</b></p> <ul style="list-style-type: none"> <li>• Oil residues</li> <li>• Asphalt</li> <li>• Fats</li> </ul>
<p>烃化合物的积垢可以用软刷和石蜡或煤油清除。 注意! 垫片接触时间应限制在 0.5 小时以内, 否则会膨胀。 下列溶剂不应使用:</p> <ul style="list-style-type: none"> <li>• 酮类 (如丙酮, 丁酮, 甲基异丁酮)</li> <li>• 酯类 (如乙酸乙酯, 乙酸正丁酯)</li> <li>• 卤化烃 (如氯森, 四氯化碳, 氟氯烷)</li> <li>• 芳香剂 (如苯, 甲苯)</li> </ul>	<p>Hydrocarbon-based deposits may be removed by using a soft brush and a PARAFFINIC or NAPHTHA-BASED solvent (e.g. KEROSENE).</p> <p><b>NOTE!</b> Gaskets in natural, butyl and EPDM rubber swell in these media. Contact time should be limited to 0.5 hour. The following solvents should not be used:</p> <ul style="list-style-type: none"> <li>• Ketones (e.g. Acetone, Methyl ethyl ketone, Methyl isobutyl ketone)</li> <li>• Esters (e.g. Ethyl acetate, Butyl acetate)</li> <li>• Halogenated hydrocarbons (e.g. Chloroethene, Carbon tetrachloride, Freons)</li> <li>• Aromatics (e.g. Benzene, Toluene)</li> </ul>